

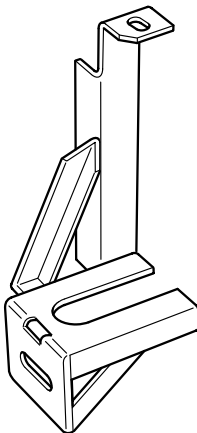

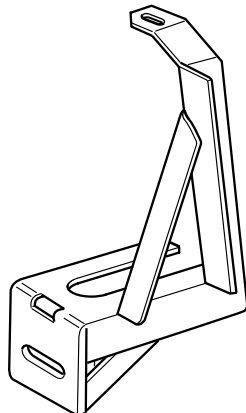

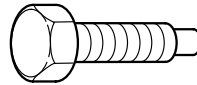





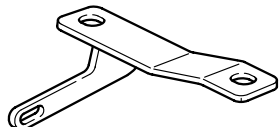
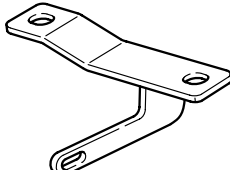
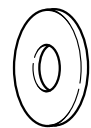
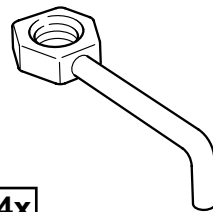
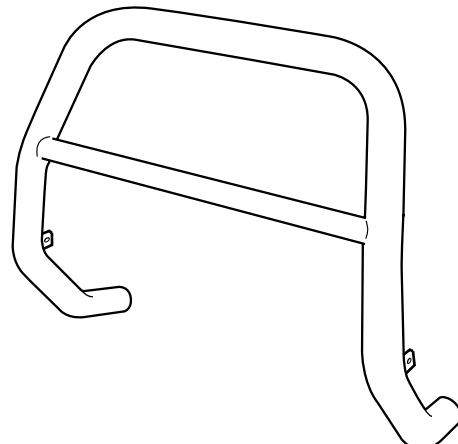
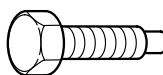

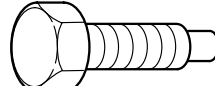

MOPAR®

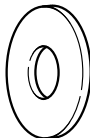
JEEP GRAND CHEROKEE

Grille Guard

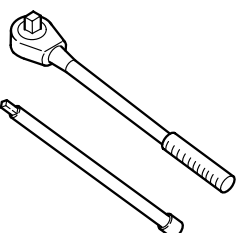
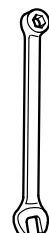
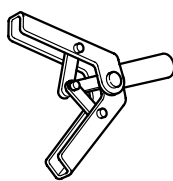
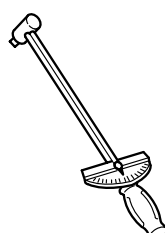
 <p>A R</p>	 <p>B L</p>	 <p>C 6x M10x30</p>	 <p>D 6x Ø10</p>			
 <p>G R</p>	 <p>H L</p>	 <p>E 6x Ø10, 5</p>	 <p>F 4x</p>			
		 <p>I</p>				
 <p>J 2x M8</p>	 <p>K 2x Ø8, 4</p>	 <p>L 4x Ø8</p>	 <p>M 2x M8</p>			
 <p>N 2x M12</p>	 <p>O 2x Ø12</p>	 <p>P 2x Ø13</p>	 <p>Q 4x</p>			
		<p>7mm 10mm 13mm 17mm 19mm</p> 		<p>13mm 17mm</p> 		

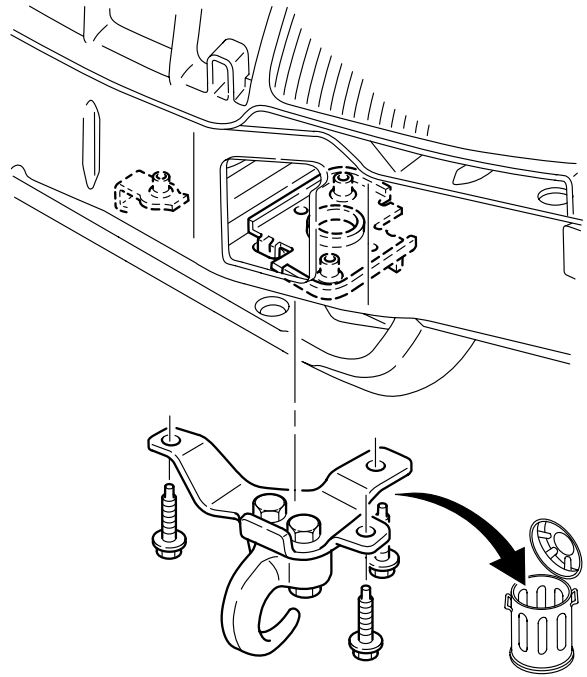
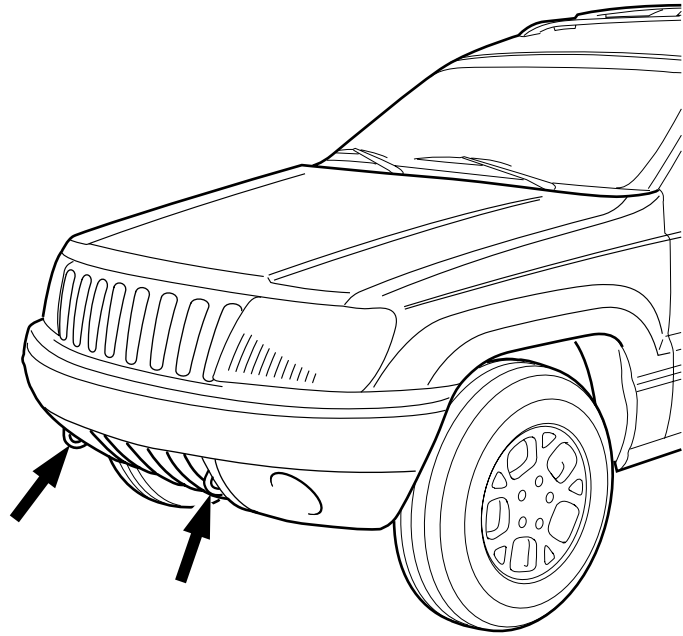

1 FRONT FASCIA CAN STAY IN PLACE. REMOVE TOW HOOKS, IF EQUIPPED. LEAVE CLIPS AND TAPPING PLATES IN PLACE.

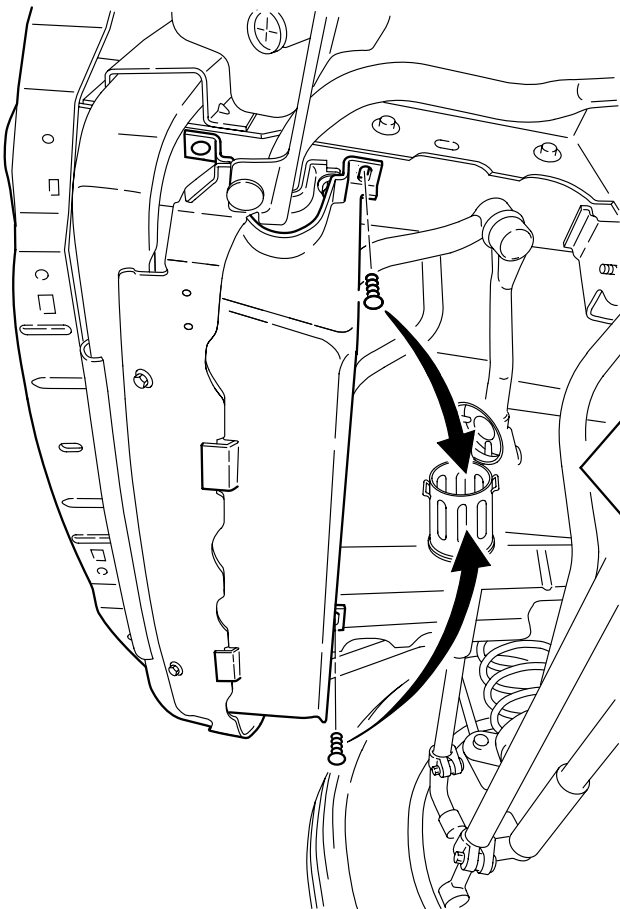

2A VEHICLES WITH FRONT SPLASH SHIELD.

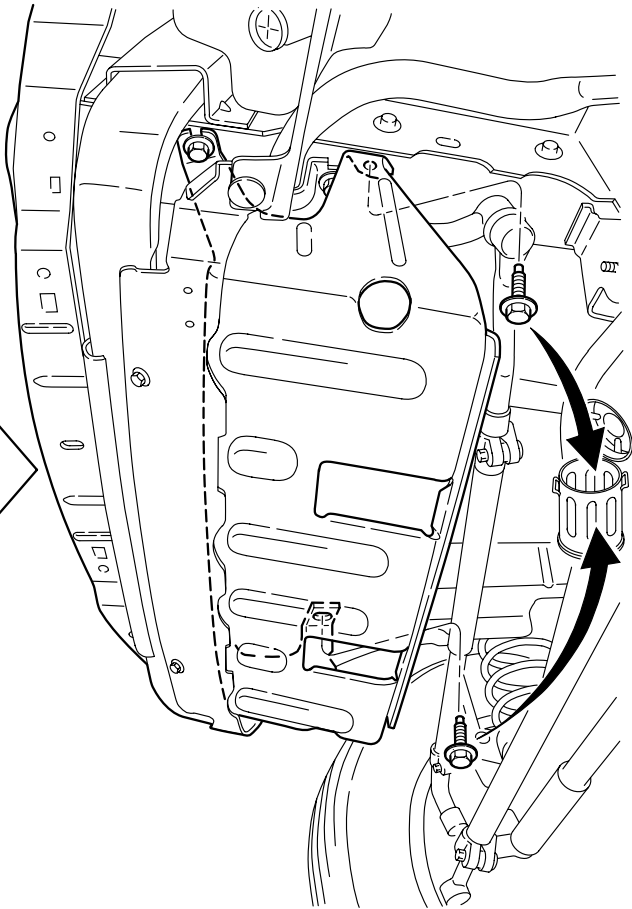

2B VEHICLES WITH FRONT SKID PLATE.

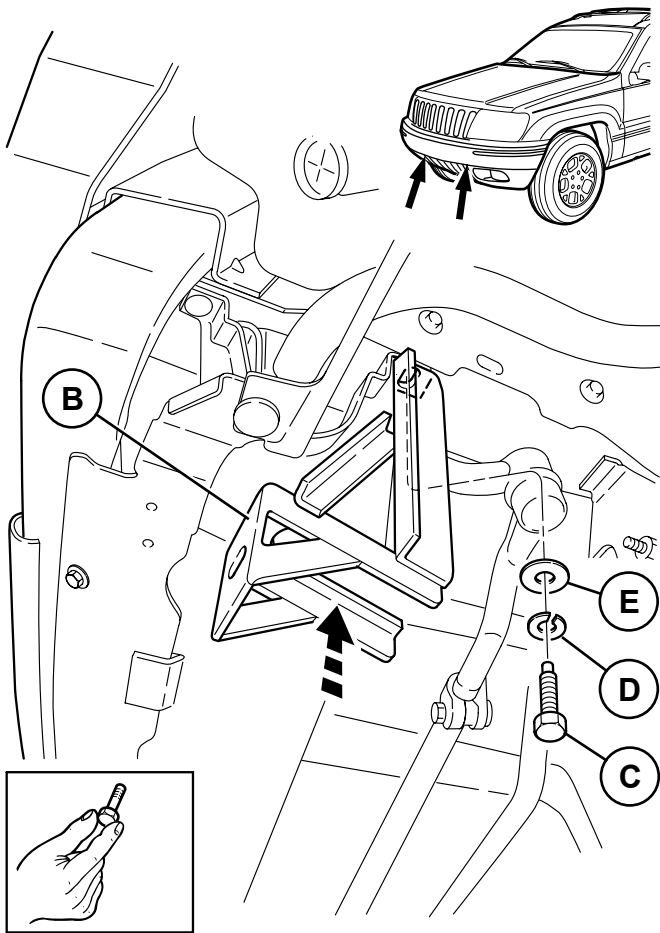

3A VEHICLES WITH FRONT SPLASH SHIELD.

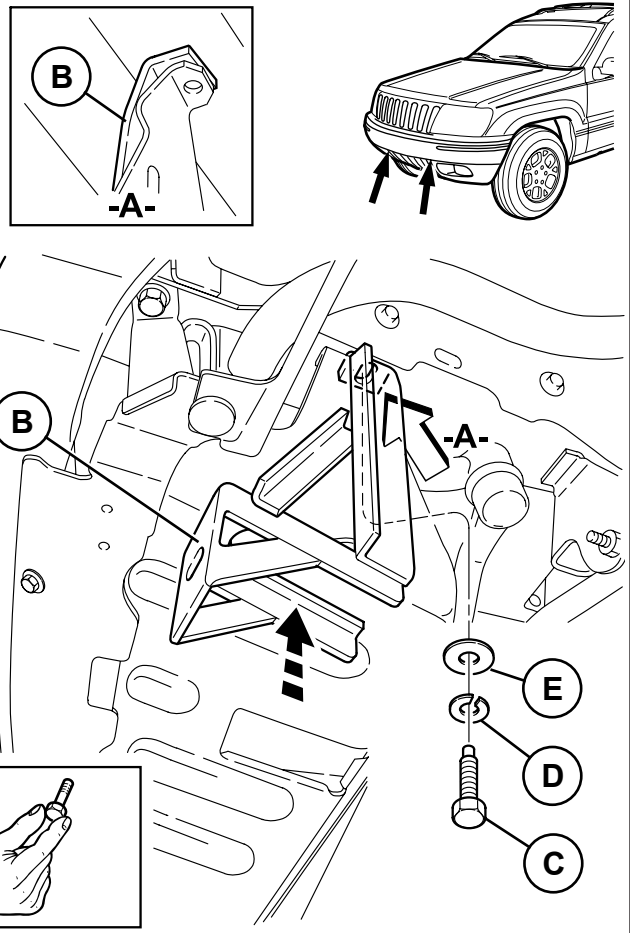

3B VEHICLES WITH FRONT SKID PLATE.

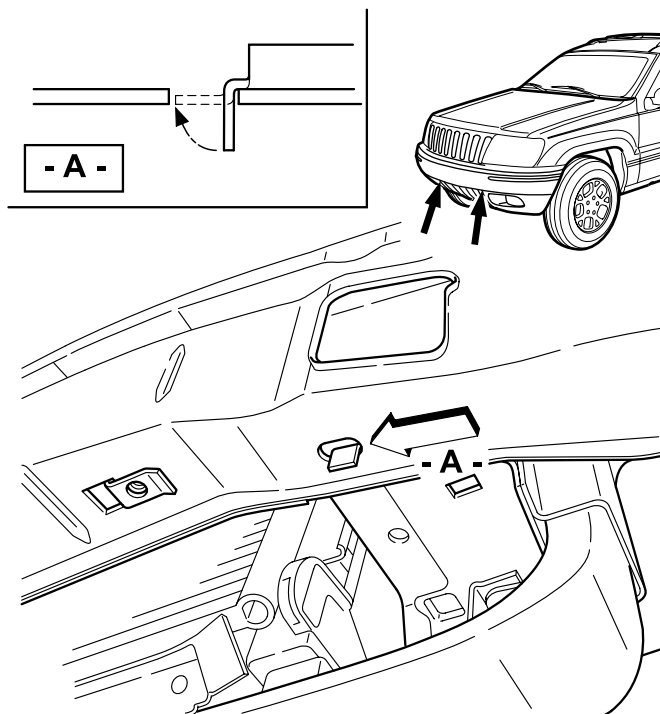

4A VEHICLES WITH FRONT TOW HOOKS.

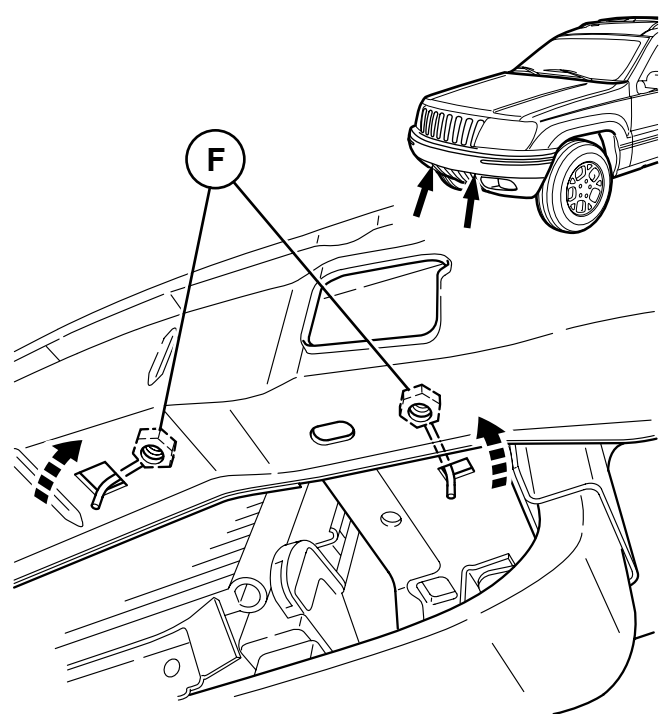

4B VEHICLES WITHOUT FRONT TOW HOOKS.

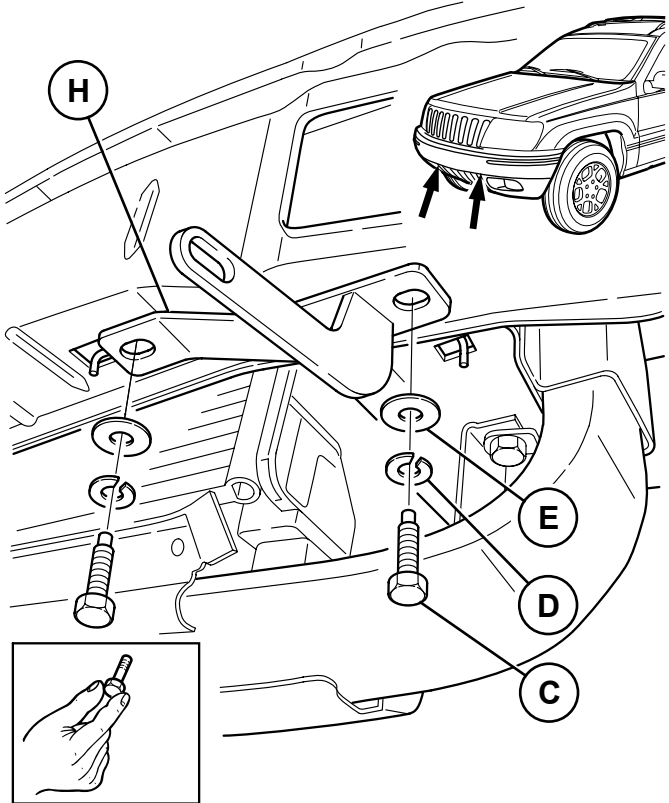

5

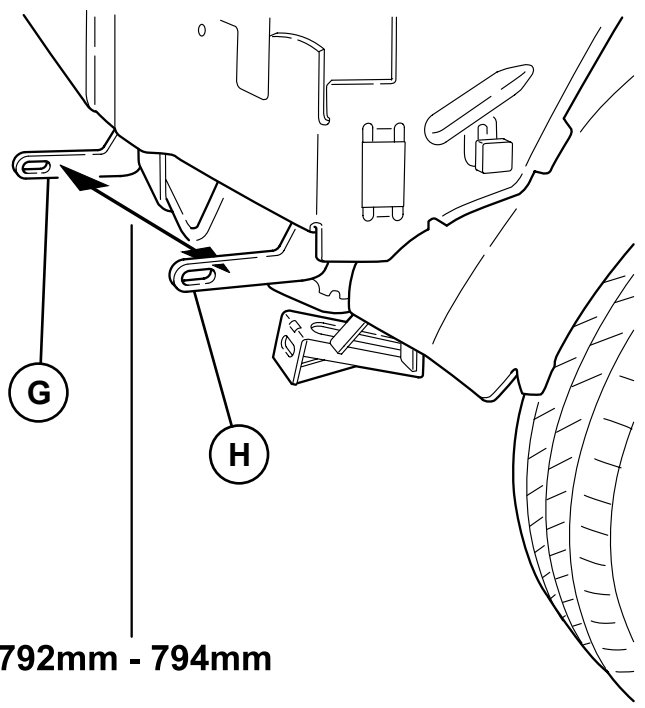

792mm - 794mm

6

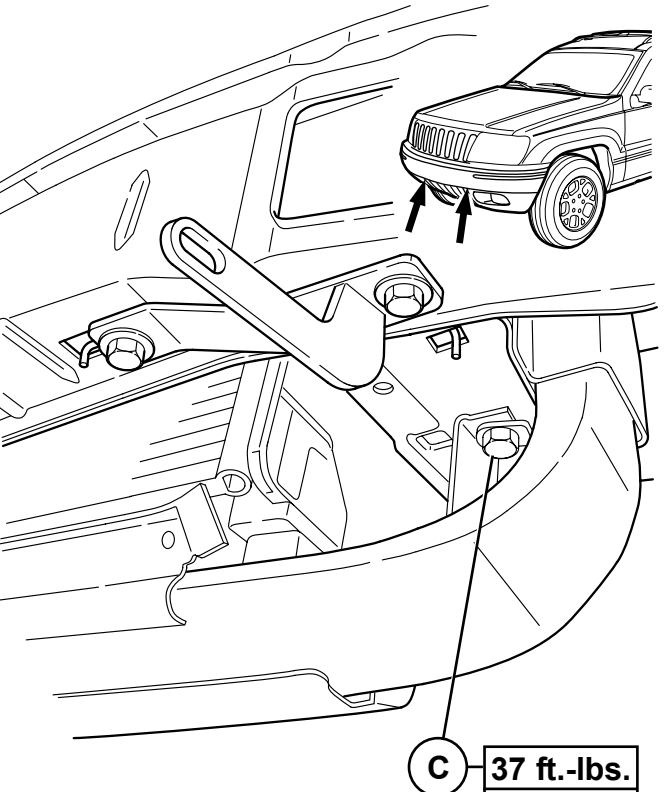

C 37 ft.-lbs.
(50 N·m)

7

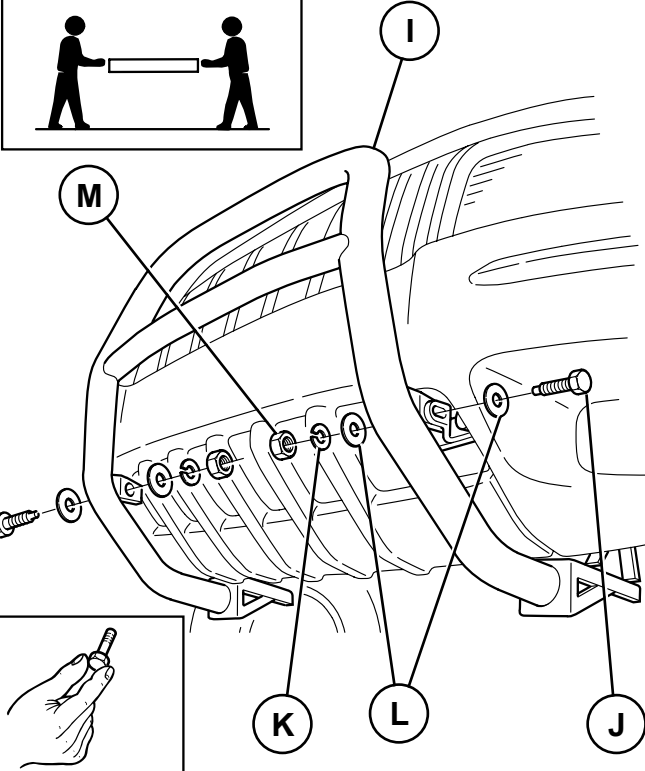

8

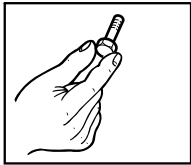
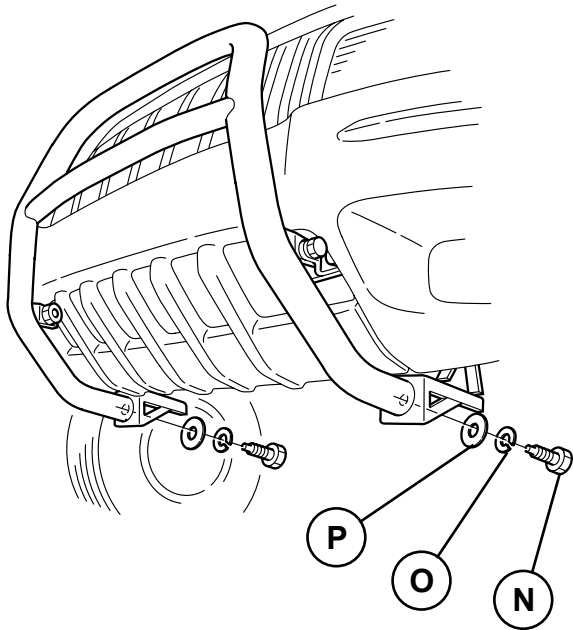

9

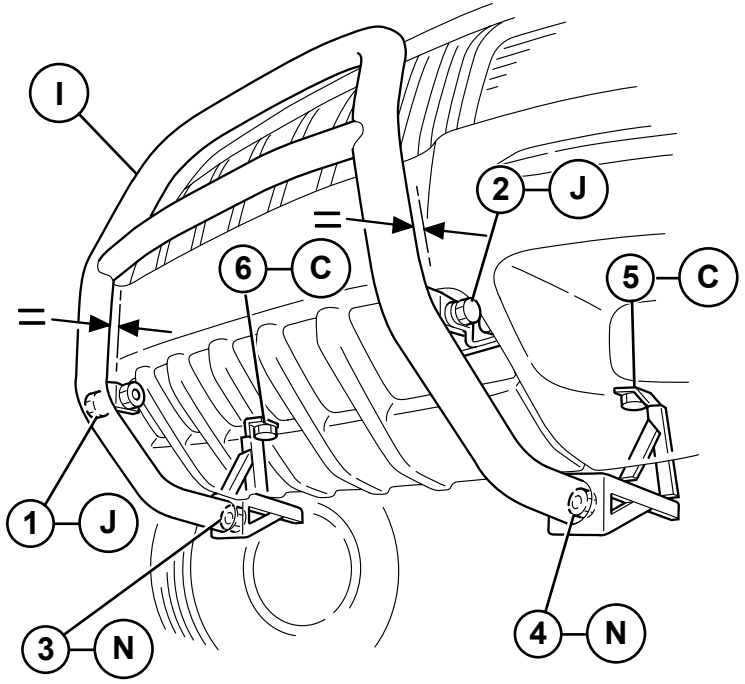

J M8 18 ft.-lbs. (25 N·m)	N M12 64 ft.-lbs. (87 N·m)	C M10 37 ft.-lbs. (50 N·m)
-------------------------------------	--------------------------------------	--------------------------------------

10

TIGHTENING SEQUENCE

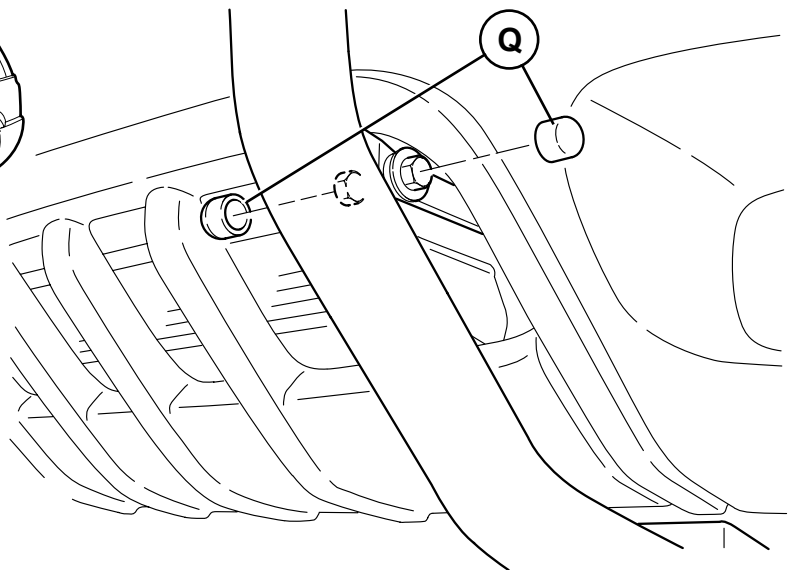
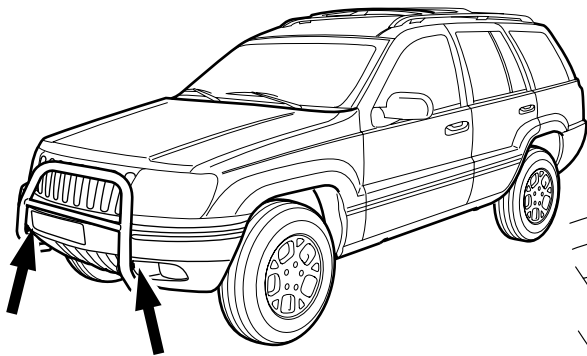

11